

1952

The mechanism of the benzidine rearrangement

Mendel David Cohen
Iowa State College

Follow this and additional works at: <https://lib.dr.iastate.edu/rtd>

 Part of the [Physical Chemistry Commons](#)

Recommended Citation

Cohen, Mendel David, "The mechanism of the benzidine rearrangement " (1952). *Retrospective Theses and Dissertations*. 13398.
<https://lib.dr.iastate.edu/rtd/13398>

This Dissertation is brought to you for free and open access by the Iowa State University Capstones, Theses and Dissertations at Iowa State University Digital Repository. It has been accepted for inclusion in Retrospective Theses and Dissertations by an authorized administrator of Iowa State University Digital Repository. For more information, please contact digirep@iastate.edu.

THE MECHANISM OF THE BENZIDINE REARRANGEMENT

by

Mendel David Cohen

A Dissertation Submitted to the
Graduate Faculty in Partial Fulfillment of
The Requirements for the Degree of
DOCTOR OF PHILOSOPHY

Major Subject: Physical Chemistry

Approved:

Signature was redacted for privacy.

In Charge of Major Work

Signature was redacted for privacy.

Head of Major Department

Signature was redacted for privacy.

Dean of Graduate College

Iowa State College

1952

UMI Number: DP12649

INFORMATION TO USERS

The quality of this reproduction is dependent upon the quality of the copy submitted. Broken or indistinct print, colored or poor quality illustrations and photographs, print bleed-through, substandard margins, and improper alignment can adversely affect reproduction.

In the unlikely event that the author did not send a complete manuscript and there are missing pages, these will be noted. Also, if unauthorized copyright material had to be removed, a note will indicate the deletion.

UMI[®]

UMI Microform DP12649

Copyright 2005 by ProQuest Information and Learning Company.

All rights reserved. This microform edition is protected against unauthorized copying under Title 17, United States Code.

ProQuest Information and Learning Company
300 North Zeeb Road
P.O. Box 1346
Ann Arbor, MI 48106-1346

QD501
C66m

TABLE OF CONTENTS

	Page
ACKNOWLEDGMENTS.....	iii
INTRODUCTION.....	1
HISTORICAL.....	4
EXPERIMENTAL METHODS AND RESULTS.....	23
Preparation of Materials.....	23
Bindschedler's Green.....	23
Lithium perchlorate (anhydrous).....	24
Hydrazobenzene.....	24
Styphnic acid.....	25
Titanous chloride solution.....	25
Sodium chloroacetate, styphnate, glycolate and cyanoacetate.....	25
Attempted preparation of hydrazobenzene dihydroiodide...	25
Benzidine dihydroiodide.....	30
Other materials.....	30
Kinetic Procedure and Analytical Technique.....	30
Variation of Reaction Rate with Change of Acid Catalyst.....	32
Variation of Rate with Concentration of Undissociated Acid..	36
Attempted Application of the Bronsted Relation.....	43
Attempted Isolation of the Rearrangement Step.....	44
DISCUSSION.....	48
Limitations Inherent in the Experimental Method.....	48
The Information Gained from this Study.....	50
Implications of the Kinetics.....	51
The Nature of the Transition-state.....	54
The Nature of the Rearrangement Step.....	58
The Thermodynamics of Pre-equilibration.....	59
The Bronsted Relation.....	62
SUMMARY.....	65

T10291

ACKNOWLEDGMENTS

The author wishes to express his deep appreciation to Dr. G.S. Hammond for his friendly and enthusiastic guidance throughout the course of this work.

Acknowledgment is also made of a United States Public Health Service Predoctoral Research Fellowship, which enabled the author to undertake this study.

INTRODUCTION

The benzidine rearrangement is the rearrangement of substituted and unsubstituted hydrazobenzenes to the corresponding benzidines. For the unsubstituted compounds the reaction is formulated:

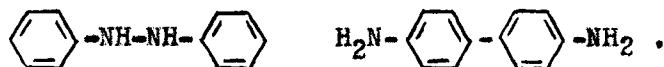

This change can sometimes be effected by application of heat alone, but is generally produced by use of acids as catalysts. In the latter case the formation of benzidine is accompanied by formation of varying amounts of diphenylins (I), o-semidine (II) and p-semidine (III).

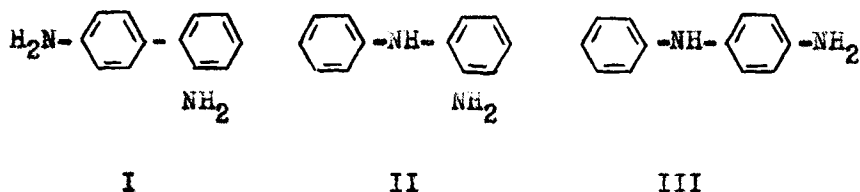

The relative proportions of these products are determined by the particular hydrazobenzene used and by the experimental conditions.

It has been known for some years that the acid catalysed rearrangement is intramolecular. It is this fact which lends special interest to a study of the mechanism involved. Intramolecularity suggests a continuous binding together of the two sections of the molecule. Thus while the new carbon - carbon linkage is being formed there must be partial bonding of the two residues, either directly through the nitrogen atoms, or by some secondary valence involving the aromatic π -electrons. In particular, the configuration of the transition-state for the rearrangement has been the subject of much speculation; for a benzene ring is known to have considerable

"thickness", yet it seemed necessary for there to be simultaneous partial bonding between the nitrogen atoms and between the carbon atoms.

During the twenty years prior to 1950, a large number of descriptions of the nature of the transition-state were formulated. All these were based on the assumption that the reaction was of first order in hydrogen ion. Thus, most workers in this field postulated that the first conjugate acid of hydrazobenzene rearranges in the rate-determining step.

In 1950 it was shown by Hammond and Shine¹ that the hydrogen ion dependence was a second order one, in fact. These authors therefore suggested that the second conjugate acid of hydrazobenzene might be the species which rearranges. There remained the question of whether

(i) the transfer of the second proton to the first conjugate acid of hydrazobenzene, or

(ii) the rearrangement of the diconjugate acid, is the rate-determining step. The former case would be of particular interest in that the transfer of hydrogen from an acid, or a protolytic solvent, to nitrogen usually takes place extremely rapidly².

The rearrangement is catalysed by mineral acids and by acids which are incompletely dissociated in solution. In the latter case the active catalytic species could be hydrogen ion, or molecular acid, or both. Catalysis by molecular acid, called general acid catalysis, is only kinetically observable when transfer of the proton from acid to reactant

¹Hammond and Shine, J. Am. Chem. Soc., 72, 220 (1950).

²Ingold and Wilson, Z. Elektrochem., 44, 62 (1938).

takes place in the rate-determining step.

It was decided to investigate more closely the type of catalysis involved in this rearrangement. If the catalysis proved to be specifically by hydrogen ion then no choice could be made between the possibilities (i) and (ii). If the rearrangement proved to be subject to general acid catalysis, however, it would indicate that the transfer of a proton to the first conjugate acid of hydrazobenzene occurs in the rate-determining step.

For the most general type of acid catalysis, the specific rate constant may be expressed in the form

$$k = k_1 [H^+] + \sum_1 k_1 [HA_1] .$$

The first term on the right represents the contribution to the overall rate by the hydrogen ion catalysed reaction. The terms in the summation are the contributions of the various molecular acids, where the k_1 's are the catalytic constants of the acids. It was decided to employ two methods of testing for general acid catalysis. Both require constant ionic strength and constant hydrogen ion concentration. Then the acid catalysis is general if there is a variation in the specific rate on replacing the acid HA_1 by acid HA_j , or if there is a change in rate with variation in the concentration of undissociated acid.

Additional evidence on the identity of the rate-controlling step could be obtained if the individual steps were isolable and their specific rates measurable. It was therefore decided to attempt to isolate the diocnjugate acid of hydrazobenzene and to determine its rate of rearrangement in a suitable solvent.

HISTORICAL

In 1845 Zinin studied the reduction of azobenzene in acid media. Almost twenty years later Fittig³ showed that the product, benzidine, is a diaminodiphenyl. Hoffman⁴, soon after, discovered hydrazobenzene and showed that it was the precursor of benzidine in the acid reduction of azobenzene. Schultz and his coworkers were the first to isolate some diphenylene⁵ from the rearrangement products. They were also able to establish the structures of benzidine⁶ and of diphenylene⁷.

Since that time the rearrangements of a considerable number of azo- and hydrazo-benzenes have been studied. Particularly as a result of the work of Jacobsen⁸ and his students the scope and limitations of the rearrangement have been fairly clearly established. The main purpose of these early investigations was to establish the effect of substituents in positions in the aromatic nuclei at which carbon - carbon linking might otherwise have been expected to occur.

The knowledge thus accumulated may be summarized, as follows. In all cases a certain amount of disproportionation occurs:

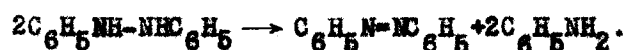

³Fittig, Ann., 124, 262 (1862).

⁴Hoffman, Proc. Roy. Soc., 12, 576 (1863).

⁵Schmidt and Schultz, Ber., 11, 1754 (1878).

⁶Schultz, Ann., 174, 227 (1874).

⁷Schmidt, Schultz and Strasser, ibid., 207, 348 (1881).

⁸Jacobsen, ibid., 428, 76 (1922).

When both para positions are free the main product is the benzidine, with smaller amounts of the diphenylene and of the ortho and para semidines, provided the appropriate positions are free. Thus



as the main product, where $X = -NH_2, -COOH, -SO_3H$ or $-CH_3$. This is also true if the hydrazobenzene is both ortho- and meta-substituted. From hydrazonaphthalene⁹ (IV), for example, the main product is the corresponding p,p'-disubstituted compound (V). However, in this case there is also formed the o,o' product (VI), or the corresponding carbazole (VII), while no o,p' product analogous to diphenylene is isolated.

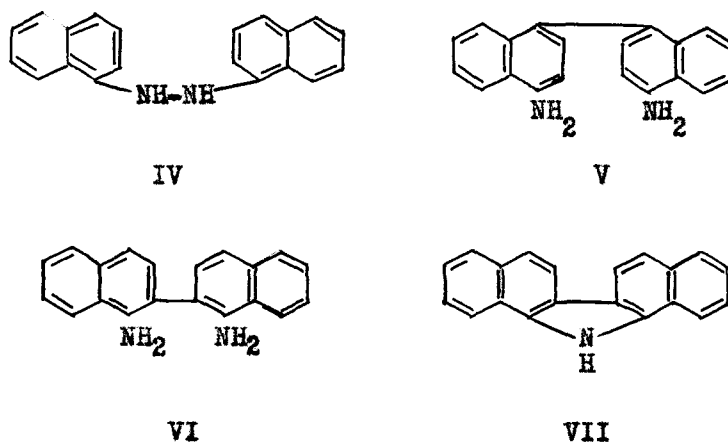

The case of hydrazobenzenes with one para position substituted is of some interest. Usually the principal product is the diphenylene. However, when the substituent is $-Cl, -SO_3H, -CO_2H$ or $-OCOCH_3$ the rearrangement often gives benzidine, with elimination of the substituent. Thus

⁹Vesely, Ber., 38, 136 (1906).

hydrazobenzene-4-carboxylic acid (VIII) yields mainly unsubstituted benzidine¹⁰.



VIII

Several examples of N-substituted hydrazobenzenes have been studied. Some of their reactions are illustrated below, the products shown being the main ones but not being formed exclusively.

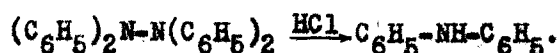

$(\text{C}_6\text{H}_5)_2\text{N}-\text{N}(\text{C}_6\text{H}_5)_2 \xrightarrow{\text{c. H}_2\text{SO}_4} \text{C}_6\text{H}_5-\text{NH}-\text{C}_6\text{H}_4-\text{C}_6\text{H}_4-\text{NH}-\text{C}_6\text{H}_5$
in small yields¹¹.

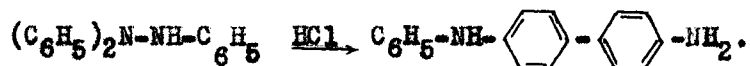

An interesting case is the rearrangement¹²



Hughes and Ingold¹³ have summarized Jacobsen's results in tabular form.

Dewar¹⁴ has developed general rules which describe the various directive influences. Considering the system A-NH-NH-B, where A is the more

¹⁰Noelting and Werner, Ber., 23, 2356 (1890).

¹¹Wieland and Gambarjan, ibid., 39, 1499 (1906).

¹²Wieland and Haas, ibid., 53, 1336 (1920).

¹³Hughes and Ingold, Quart. Rev., 6, 34 (1952).

¹⁴Dewar, Nature, 176, 784 (1945).

basic aromatic ring, he formulated the rules as follows¹⁴:

(i) The ease of reaction is in the order benzidine > diphenylene > semidine.

(ii) Only the para position in A can take part in diphenylene formation. Thus in 4-chlorohydrazobenzene, where the unsubstituted ring is A, benzidine formation does not take place unless elimination occurs. The main product is 2,4'-diamino-5-chlorobiphenyl (IX).

(iii) In semidine formation A carries the $-NH_2$ in the product. Thus, for 4-methoxyhydrazobenzene, benzidine cannot be formed and diphenylene is not formed as the para position of A is substituted. The product found is 2-amino-5-methoxydiphenylamine (X).

(iv) Disproportionation probably occurs in all cases but is independent of the rearrangement.

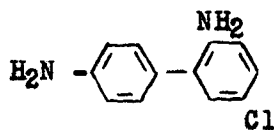

IX

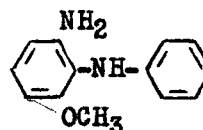

X

In recent years the search for new synthetic applications of the rearrangement has decreased in intensity. Instead emphasis has been placed on the question of the mechanism - a question which has aroused considerable interest and controversy.

An early suggestion was that semidines, often isolated from the reaction mixtures, are the precursors of the corresponding benzidines¹⁵. However, Robinson¹⁶ showed that semidines do not form benzidines under the conditions of the rearrangement. Thus semidine and benzidine formation appear to be independent and simultaneous.

It is conceivable that the rearrangement proceeds by initial fission of the hydrazobenzene into fragments which then recombine to give the

¹⁵Lapworth, J. Chem. Soc., 73, 451 (1898).

¹⁶Robinson and Robinson, ibid., 113, 639 (1918).

products. It has been suggested, in turn, that radicals¹⁷, ions and molecules¹⁸ are the reactive fragments. There is strong evidence that no such fission is involved in the reaction. Jacobsen⁸ studied the rearrangement of a large number of molecules C-NH-NH-D, where C and D are different aromatic systems. In no case was any product containing two C nuclei, or two D nuclei, isolated.

This failure to find cross-products is not valid proof against initial heteropolar fission. If

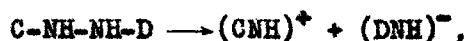

the absence of cross-products may be due to electrostatic repulsion between ions of like charge. For this reason Ingold and Kidd¹⁹ studied the rearrangement of 2,2'-dimethoxy- and 2,2'-diethoxy-hydrazobenzenes, which undergo the reaction at comparable rates and with formation of benzidines, mainly. They found no evidence for cross-products. Similarly, Wheland and Schwartz²⁰, using a tracer method, concluded that if there are any cross-products they constitute less than one percent of the total products of the rearrangement.

Further evidence against initial fragmentation is obtained from studies of molecules such as tetraphenylhydrazine, which are known to be partially dissociated into free radicals under certain conditions. Under

¹⁷Jones and Kenner, J. Chem. Soc., 1848 (1931); 711 (1932).

¹⁸Steiglitz, J. Am. Chem. Soc., 25, 62 (1903).

¹⁹Ingold and Kidd, J. Chem. Soc., 984 (1933).

²⁰Wheland and Schwartz, J. Chem. Phys., 17, 425 (1949).

the same conditions no rearrangement occurs¹¹. Evidence against intermolecularity was obtained by Bloink and Pausacker²¹ in their studies of the rearrangements of 2- and 3-carboxyhydrazobenzenes. Finally, molecular pairs like $C_6H_5NH_2$ and C_6H_5NHOH , which might be postulated as intermediates, do not react to give benzidine.

Identification of the products of the rearrangements of various substituted hydrazobenzenes thus led to the conclusion that the rearrangement is an intramolecular one. In subsequent work the centres of interest have been the questions of the nature of the transition-state and of the driving force for the rearrangement.

During the initial period of study of the mechanism kinetic evidence was scanty. In 1904, van Loon²² found that the rate is of first order in hydrazobenzene and suggested that the hydrogen ion dependence was a second order one. However, the latter aspect of the work is of doubtful value since ionic strengths were not controlled. Twenty years later Billman and Blom²³ measured the rate electrometrically and suggested that there was a one-half order dependence on hydrogen ion.

Some thirty-five years ago Robinson¹⁵ was interested in the synthesis of highly substituted pyrroles. He arrived at a synthesis through application of a series of analogies and by postulating a mechanism for the benzidine rearrangement. It is of interest that his mechanism allows for intramolecularity.

²¹Bloink and Pausacker, J. Chem. Soc., 950 (1950).

²²van Loon, Rec. Trav. Chim., 23, 162 (1904).

²³Billman and Blom, J. Chem. Soc., 125, 1719 (1924).

Robinson first considered the Fischer indole synthesis which, he suggested, might take place through some such path as:

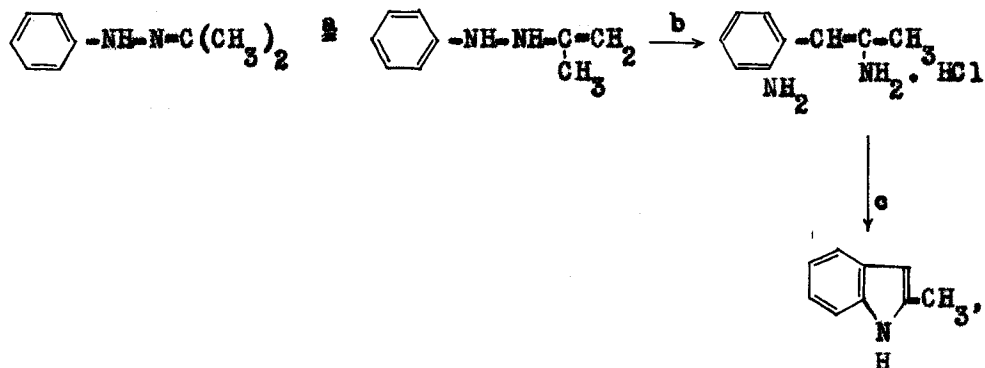

the whole reaction proceeding under the influence of hydrochloric acid and heat. Here step b utilizes an α -benzidine type rearrangement, which Robinson compared with the formation of carbazoles from hydrazonaphthalenes. He treated this as a specific case of the rearrangements of the system A-b-c-D, where A and D are unsaturated groups and either b, or both b and c, can attain a higher valence state by salt formation. This system, on activation by acid, can undergo the following series of changes:

- (i) form $\text{A}-\overset{\cdot}{\text{b}}\dots\overset{\cdot}{\text{c}}-\text{D}$, where dotted lines represent "partial bonds",
- (ii) these partial bonds conjugate with A and D, to give $\overset{\cdot}{\text{A}}\dots\overset{\cdot}{\text{b}}\dots\overset{\cdot}{\text{c}}\dots\overset{\cdot}{\text{D}}$, which
- (iii) can close to form a ring.

This treatment is reminiscent of that of Thiele for conjugated unsaturated systems. Thus Robinson's mechanism for the indole synthesis was formulated as:

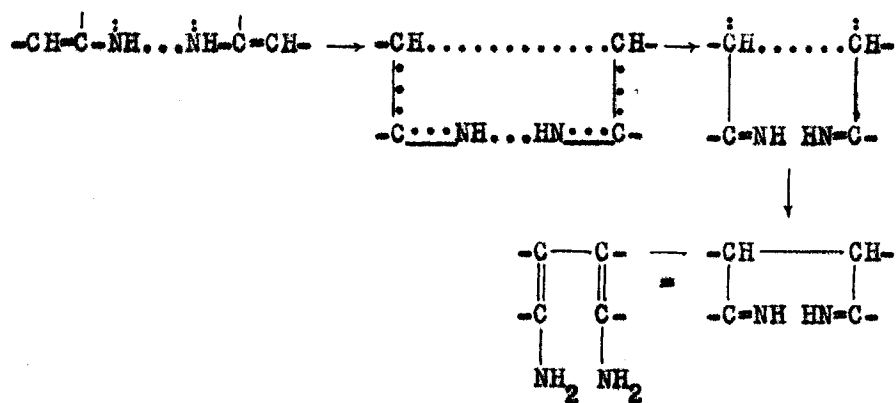

It is noted that the partial bonds allow for the continuous binding together of the two sections of the molecule. Finally, by analogy, Robinson suggested that the following reaction sequence might be feasible for the pyrrole synthesis:

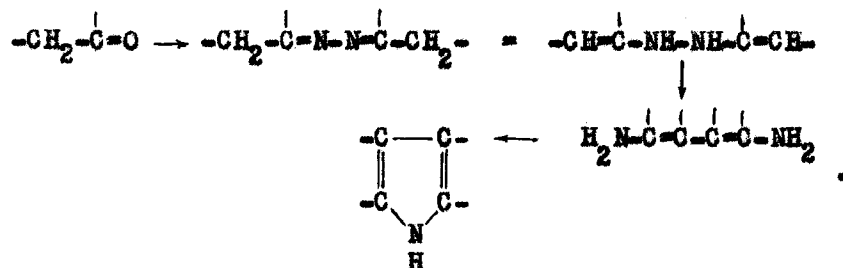

In fact, he obtained tetraphenylpyrrole, in almost quantitative yield, by treating bis-phenylbenzylketazine (XI) with dry hydrogen chloride.



XI

Robinson's synthetic procedure has recently been extended by Theilacker²⁴. This worker showed that acetophenonephenylhydrazone yields 2-phenylindole on heating with strong acid. Benzophenonephenylhydrazone, however, apparently undergoes the following series of

²⁴Huckel, "American F.I.A.T. Review of German Science, 1939-1946", Vol. 34, Leibiger Research Laboratories, Petersburg, N.Y., 1951, p. 182.

changes:

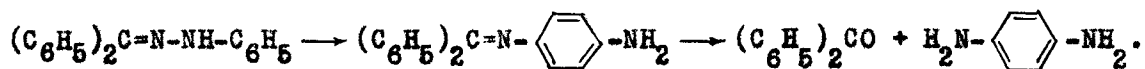

When the appropriate para position is substituted the products are mainly ammonia and tar.

Other work^{25,26,27} in this direction has produced an unusual variation. It was shown that rearrangement of a di-ortho-substituted phenylhydrazone may lead to elimination of an ortho substituent. Thus, 2,6-dichlorophenylhydrazones (XII) have been found to give 5,7-dichloroindoles (XIII), on treatment with zinc chloride.

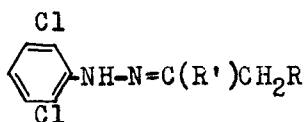

XII

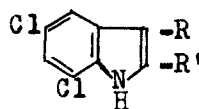

XIII

That non-benzenoid unsaturated systems can participate in the rearrangement has been long established. A glyoxaline nucleus²⁸, for example, can replace a benzene ring, and rearrangement still occurs:

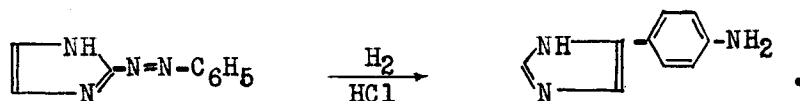

It has been suggested that for the rearrangement to take place the benzene rings must become parallel in the course of thermal motion.

²⁵Carlin and Fisher, *J. Am. Chem. Soc.*, **70**, 3421 (1948).

²⁶Barnes, Pausacker and Badrock, *J. Chem. Soc.*, 730 (1951).

²⁷Carlin, Wallace and Fisher, *J. Am. Chem. Soc.*, **74**, 990 (1952).

²⁸Pyman and Raval, *J. Chem. Soc.*, **117**, 1428 (1920).

This is considered very improbable unless allowance is made for the participation of at least one proton in the transition-state. It is known from studies on the structures of crystalline benzene complexes, for example, that it is difficult for two aromatic nuclei to approach face to face to a distance less than three times the normal carbon - carbon single bond distance. Further information is derived from cases in which the benzene rings are constrained to lie in such a position. Thus, in *p,p'*-dimethylene-1,2-diphenylethane (XIV), in which the two aromatic "planes" are 3.09Å⁰ apart, the overlap of π-electrons introduces such a strain as to cause puckering of the benzene rings^{29,30}. In addition, it is probable that if the rearrangement proceeded by such a mechanism the activation energy would be very high, whereas the experimental value³¹ is only about 18 Kcals. per mole.

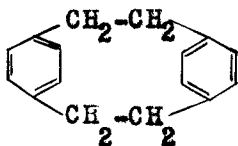

XIV

A series of workers have formulated hypothetical mechanisms based on the assumption that the species which rearranges is the first conjugate acid of hydrazobenzene.

Robinson³² suggested that in this reaction, as in others, a series of

²⁹Brown and Farthing, Nature, 164, 915 (1949).

³⁰Cram and Steinberg, J. Am. Chem. Soc., 73, 5691 (1951).

³¹Dewar, J. Chem. Soc., 777 (1946).

³²Robinson, ibid., 220 (1941).

partially compensating electron oscillations is involved. In simplified form his theory can be represented as follows:

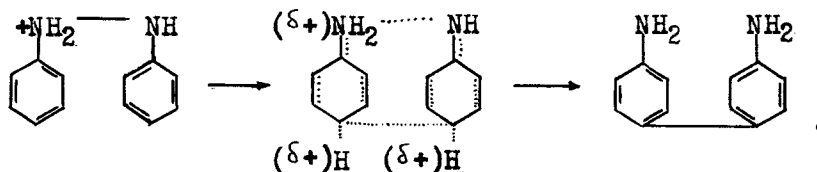

Robinson's theory, as stated, is both complicated and obscure. It tends to overemphasize the location of specific electrons and the chronology of electron-movement. It has the advantage that it allows for partial quinoid structure in the transition-state. A suitable buckling of the rings might allow the steric problem involved to be partially overcome.

Hughes and Ingold³³ objected to the fact that Robinson's mechanism required a recession of electrons from positively charged nitrogen.

They therefore suggested that the process is a concerted one:

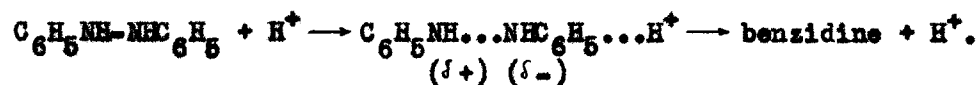

The dotted lines indicate that the ionic residues are continuously held together by electrostatic forces. The cationic portion then attaches to the negatively charged nucleus in an electrophilic aromatic substitution reaction.

Such a mechanism cannot be kinetically differentiated from that in which the first conjugate acid of hydrazobenzene rearranges in the rate-determining step. Both of these mechanisms require a mono-positively-charged transition-state in which, it is implied, there is participation

³³Hughes and Ingold, J. Chem. Soc., 606 (1941).

by structures such as

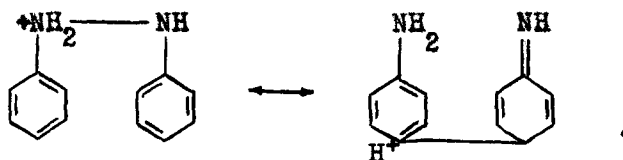

Both the mechanism of Robinson and the mechanism of Hughes and Ingold postulate simultaneous nitrogen - nitrogen and carbon - carbon bonding. Hammick and Mason³⁴ pointed out the unattractive steric aspects of such transition-states. These authors suggested that it is the first conjugate acid of hydrazobenzene which rearranges, and that this acid is a resonance hybrid receiving appreciable contributions from such structures as



Such a charge distribution would allow for a weakened nitrogen - nitrogen bond while there is an electrostatic attraction between the para carbon atoms, which can be operative over a distance large compared to the covalent bond length. It is noteworthy that such a charge distribution now appears more naturally, as a result of recent kinetic studies. Contributions from quinoid structures, as shown, also allow for closer approach of the terminal carbon atoms.

Attractive as such a scheme is, for the above reasons, it must be considered highly improbable insofar as energy factors are concerned. Dewar³⁵ proposed to overcome the stereochemical difficulties by an

³⁴Hammick and Mason, J. Chem. Soc., 638 (1946).

³⁵Dewar, ibid., 406 (1946).

alternative approach. As in the Hughes-Ingold treatment, heteropolar fission occurs with neutralization of the charge on the negative fragment by a proton. The difference between the two treatments lies in the type of partial bonding envisaged to hold the segments together. Dewar suggested that the bonding is not localized between the nitrogen atoms but that the aromatic systems can be linked along their lengths. This type of bonding, yielding a " π -complex", involves the π -electrons of the neutral fragment and the vacant π -orbital of the cation. The concept of π -complexes has been developed extensively by Dewar³⁶ and these complexes have been postulated, by him, as intermediates in electrophilic aromatic substitution reactions. Thus the nature and proportions of the products formed in the rearrangement can be predicted, by this token, on the basis of the rules for normal electrophilic substitution.

Dewar's quantum mechanical treatment of systems involving π -complexes is, perforce, based on a large number of simplifying assumptions³⁷. Nevertheless, the concept is a useful one on which can be based formulations of many reaction paths. It seems surprising that workers of the calibre of Hughes and Ingold, Robinson and Dewar should have pondered at such length on the mechanism of the benzidine rearrangement without establishing the correctness, or otherwise, of the assumption of first order hydrogen ion dependence.

That this assumption might be incorrect, in fact, was suggested by

³⁶Dewar, "The Electronic Theory of Organic Chemistry", Oxford University Press, London, 1949.

³⁷Coulson and Dewar, Disc. Farad. Soc., No. 2, "The Labile Molecule", 54 (1947).

the work of Pongratz and his co-workers^{38,39}. These workers heated azobenzene and, separately, hydrazobenzene with methyl iodide in a sealed tube, with or without methanol as solvent. In all cases they obtained methylated benzidines as products. They formulated the reaction with hydrazobenzene as:

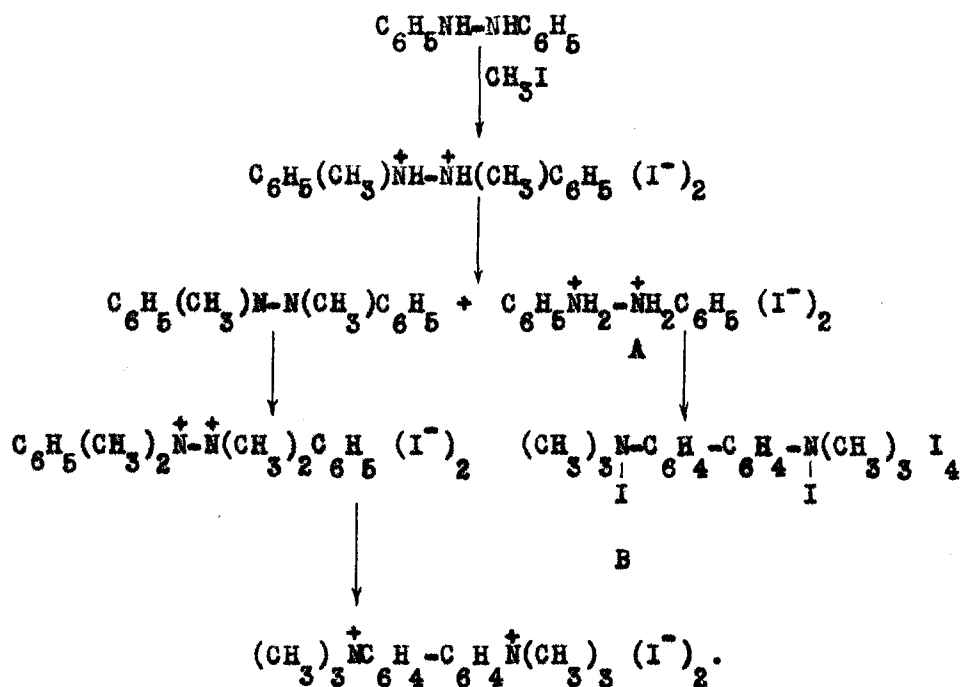

Compound B could probably be more accurately represented as

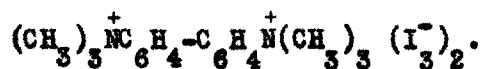

The authors stated that compound A can actually be isolated from solution after a short while at a comparatively low temperature. Similarly they obtained crystals of the dihydrobromide of hydrazobenzene from methyl bromide solution at room temperature. It was suggested that these salts

³⁸Pongratz and Wustner, Ber., 73, 423 (1940).

³⁹Pongratz and Scholtis, ibid., 75, 2369 (1942).

of the diacid are functional intermediates in the rearrangement, since on solution in a suitable solvent they are converted into fully methylated benzidine. Pongrats suggested that the course taken by the rearrangement might be

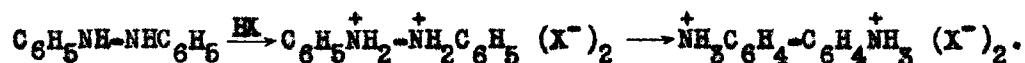

Finally, in 1950, the hydrogen ion dependence of the acid catalysed benzidine rearrangement was established unequivocally by Hammond and Shine¹. These workers found that the rate varies with the square of the hydrogen ion concentration, under conditions of constant ionic strength. They therefore suggested that the overall mechanism is:

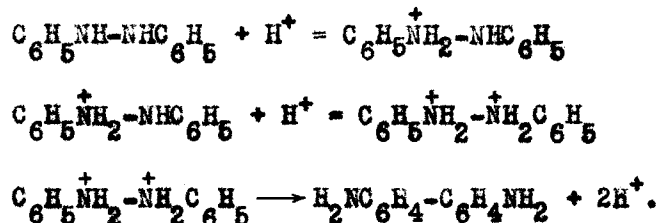

If the diacid is the rearranging species it allows for a much more reasonable picture of the transition state. The adjacent positive charges cause a weakening of the nitrogen - nitrogen bond, the electrons of which can conjugate with the aromatic nuclei:

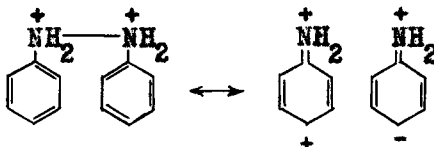

There could thus be a continuous separation of like charges while the unlike charges come together⁴⁰. This formulation allows of a satisfactory solution of the steric problem.

⁴⁰Hughes and Ingold, *J. Chem. Soc.*, 1638 (1950).

Subsequently, Carlin, Nelb and Odioso⁴¹ confirmed that the hydrogen ion dependence is a second order one. These workers measured the rates of formation of the individual products of the rearrangement. They showed that for the hydrochloric acid catalysed rearrangement of unsubstituted hydrazobenzene at 25°C. the amount of semidine formed is negligible. They demonstrated, further, that the activation energy is the same for the formation of benzidine as for the formation of diphenylene. In terms of the mechanism of Hammond and Shine, this suggests that the transition-state approximates the structure of the diconjugate acid more closely than it does the structures of the products. Carlin and co-workers presented some evidence which supports the belief that the benzidine rearrangement may occur in the solid state. They therefore suggested that the intervention of solvent molecules is not necessary either to bring about the reaction or to hold portions of the molecule together while intramolecular rearrangement occurs. Finally, they gave some results which indicate that the rearrangement of the diconjugate acid occurs very rapidly in comparison to the rate of the overall reaction.

Hughes and Ingold¹³ have recently published a review on aromatic rearrangements which includes an extensive section on the mechanism of the benzidine rearrangement. These authors stated that Hammond and Shine had proved that the catalysis was specifically by hydrogen ion. On this basis they discussed the forces which stabilize the transition-state and

⁴¹Carlin, Nelb and Odioso, J. Am. Chem. Soc., 73, 1002 (1951).

allow the occurrence of a reaction which seems so improbable stereochemically. The transition-state which they described is intermediate in structure between the diconjugate acid of hydrazobenzene and the products of reaction. They pointed out that there can be considerable interaction between the electrons originally comprising the nitrogen - nitrogen bond and the aromatic π -electrons. Thus the transition-state they pictured is a resonance hybrid of such structure as:

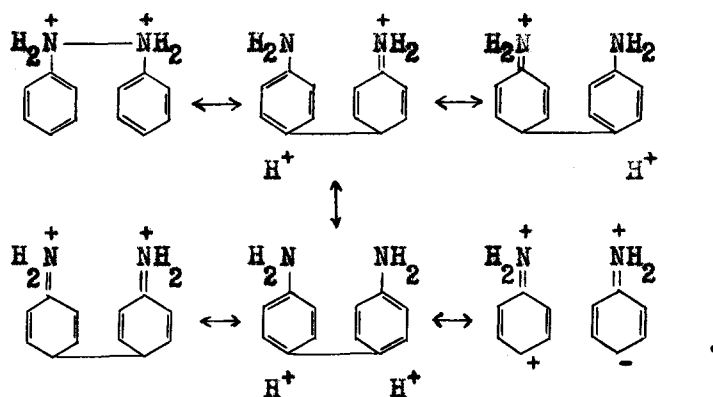

Hughes and Ingold's statement of the principle of resonance* stabilization is refreshing:

These are the octet-preserving routes by which any one of these structures can be converted into any other: some involve circulation of the electrons one way around, some the other way, and some either or both ways. The essence of this theory is that the existence of all this free intercommunication..... between the different conventional electron distributions, and, of course, between the infinitude of intermediate unconventional ones, determines, on account of the uncertainty principle, a very strong transition-state, one able, and even prone, to form itself, despite its great difference of shape from that of any normal molecule.

The authors interpreted the preference for benzidine over diphenylene formation to the greater electron disturbance, and therefore greater

*Reference 13, p.60.

uncertainty, associated with the establishment of the transition-states involved para than with ortho rearrangements.

It has long been realized that the rearrangement of hydrazobenzene into benzidine is energetically favorable, in that it involves a change from a weak to a comparatively strong base under acid conditions⁴². In addition, it entails a transformation from two practically isolated benzene rings to a conjugated biphenyl system. On the basis of these considerations alone, a heat of rearrangement of the order of 35 Kcals. per mole might be expected⁴³.

The published value for the heats of combustion of the various compounds involved in the rearrangement have been somewhat inconsistent, until recently. Thus "Landolt-Bornstein Tabellen" have values varying from 1589.0 to 1605.5 Kcals. per mole, for hydrazobenzene, and from 1557.8 to 1565.1 Kcals. per mole, for benzidine.

These thermochemical properties have been redetermined by Pongratz and Roth⁴³. Some of their results are presented in Tables 1 and 2.

Despite the large energy difference, N,N'-diacetylhydrazobenzene does not rearrange to the corresponding benzidine. Instead, hydrolysis to the N-acetylhydrazobenzene takes place, followed by rearrangement to N-acetylbenzidine. It is interesting to note that the salts of the di-conjugate acid, which are apparently intermediates in the rearrangement,

⁴²Tichwinsky, J. Russ. Phys. Chem. Soc., 35, 667 (1903), Chem. Centr., 74, II, 1270 (1903).

⁴³Pongratz, Bohmert-Suss and Scholtis, Ber., 77, 651 (1944).

Table 1

Heats of Combustion of Some Hydrazobenzenes and Benzidines
(Kcals. per mole)

Compound	Heat of Combustion	Difference
Hydrazobenzene (HB)	1590.4 \pm 0.3	
Benzidine (B)	1555.4 \pm 0.3	35.0 \pm 0.4
N-acetyl HB	1792.9 \pm 2.8	
N-acetyl B	1756.1 \pm 2.4	36.8 \pm 3.7
N,N'-diacetyl HB	2006.3 \pm 1.1	
N,N'-diacetyl B	1938.4 \pm 1.4	67.9 \pm 1.8
HB. 2HI	1644.8 \pm 6.0	
B. 2HI	1577.0 \pm 6.0	67.8 \pm 8.4

Table 2

Heats of Some Reactions Related to the Benzidine Rearrangement
(Kcals. per mole)

Reactant	Product	Heat
HB	B. 2HCl	50.00 \pm 0.17
N-acetyl HB	N-acetyl B. 2HCl	51.74 \pm 0.19
B	B. 2HCl	25.43 \pm 0.06
N-acetyl B	N-acetyl B. HCl	16.55 \pm 0.10

are relatively very high energy species. Unfortunately, the heats of rearrangement and the heats of neutralization are not directly comparable, since they were not determined under identical conditions.

EXPERIMENTAL METHODS AND RESULTS

Preparation of Materials

Bindschedler's Green

A modification of the method of Wieland⁴⁴ was used. Thirty grams of dimethylaniline, free of the monomethyl compound, was measured into a 600 ml. beaker containing 100 ml. concentrated hydrochloric acid, and cooled below 5°C. A solution of 18 grams of sodium nitrite in 30 ml. of water was added slowly, with stirring, from a funnel with the stem dipping below the liquid surface. The temperature was kept below 8°C. The product was kept stirred for a further hour, filtered, and the residue washed with 40 ml. of 1:1 hydrochloric acid, drained well, and washed with a little ethanol.

The resultant *p*-nitrosodimethylaniline hydrochloride was transferred, with the aid of 70 ml. of water, into a one litre beaker containing 275 ml. of concentrated hydrochloric acid and 55 ml. of water. This was cooled below 0°C. One hundred and fifty grams of zinc dust was added slowly, with stirring, so that the temperature remained below 5°C. Stirring was maintained for a further hour. The product was then filtered, the zinc being kept damp. The filtrate was cooled to 0°C.

Thirty grams of dimethylaniline was dissolved in 30 ml. of concentrated hydrochloric acid and 20 ml. water, and the solution cooled to 0°C. Then the solution and the above filtrate were mixed in a one litre beaker. To this was added, dropwise, a solution of twenty-eight grams of sodium bichromate in a minimum volume of water. The rate of addition was

⁴⁴Wieland, Ber., 48, 1087 (1915).

controlled to keep the temperature below 15°C. Stirring was continued for ten minutes. The resultant suspension was filtered at a pump, using a large Buchner funnel. As much water as possible was removed by applying suction in a closed system. The green dye was then washed repeatedly with anhydrous ethanol until the filtrate came through colorless. Finally, the dye was washed twice with anhydrous ether. The product was vacuum-desiccated over silica gel and anhydrous barium perchlorate. The yield of the dye was 60 grams.

It was found to be of some importance to thoroughly remove all traces of water in the final stages. The product thus prepared appears to be stable indefinitely in the solid state and decomposes very slowly in aqueous solution.

Lithium perchlorate (anhydrous)

Anhydrous lithium perchlorate was prepared from lithium carbonate and perchloric acid by the method of Roberts and Warren⁴⁵.

Hydrazobenzene

Hydrazobenzene was prepared according to Hickinbottom⁴⁶. It was recrystallized from petroleum ether (fraction boiling 65°-100°C.) immediately before use.

M.p. 129.0°-129.5°C. (uncorr.)

⁴⁵Roberts and Warren, J. Am. Chem. Soc., 72, 4869 (1950).

⁴⁶Hickinbottom, "Reactions of Organic Compounds", Longmans Green and Co., London, 1948, p. 119; p. 352.

Styphnic acid

Styphnic acid was prepared according to Hickinbottom⁴⁶.

Titanous chloride solution

Twenty five ml. of 20%, analytical grade, titanous chloride (Fisher Scientific Co.) was measured into an oxygen-free solution of 150 ml. concentrated hydrochloric acid in 2750 ml. water. A nitrogen atmosphere was maintained in the stock bottle and in the attached automatic burette.

Sodium chloroacetate, styphnate, glycolate and cyanoacetate

A solution of sodium ethoxide in ethanol was added, dropwise, to a stirred solution of the acid in ethanol, in an atmosphere free of carbon dioxide. Excess acid was used. Stirring was continued for thirty minutes after all the base had been added. The salt was separated by filtration. It was purified by recrystallization from methanol, or ethanol. Sodium chloroacetate, prepared in this way, was found to be 99% pure by titration against perchloric acid in glacial acetic acid⁴⁷.

Attempted preparation of hydrazobenzene dihydroiodide

An attempt was made to prepare hydrazobenzene dihydroiodide by the method of Pongratz⁴³, the system being maintained under a nitrogen atmosphere. A yellow solid was separated and unchanged hydrazobenzene extracted with ether. It was not possible to establish unequivocally the nature of the product. It decomposes, on heating, over a five-degree range, 170°-175°C. (uncorr.), whereas Pongratz's product decomposes

⁴⁷Fritz, Anal. Chem., 22, 1028 (1950).

at 210°C. No suitable solvent was found for recrystallization, hydroxylic solvents being avoided for fear of inducing rearrangement. The product is soluble in water and in ethanol, but is insoluble in acetone. Potentiometric titration with silver nitrate⁴⁸ gave the figure of 53.9% for the iodide content of the compound, as compared with the calculated value of 57.8%. By titration with base in aqueous solution, the equivalent weight as an acid was found to be 254, while the calculated equivalent weight is 220. Only one end-point was observed in the latter titration. This suggests that, if the compound is a dibasic acid, either the second end-point is not observable in water or the two pK values are of similar magnitudes. This is certainly not the case for the diacid from hydrazobenzene. However, the two amino-groups in benzidine are of similar basicity, the base pK's being 9.03 and 10.25. It would seem, then, that at least at the end of the titration the species in solution is benzidine. Further, an approximately 0.002 molar solution of the compound in water has a pH of 4.90. If the acid present in solution were the diconjugate acid of hydrazobenzene, which must be a strong acid, the pH would be expected to be considerably lower.

An attempt was made to titrate the compound, dissolved in ethanol, with aqueous Bindschedler's Green. The initial rate of decolorization was fairly rapid, but this rate soon decreased markedly. After only one quarter of the theoretical amount of the dye had been added, no fading

⁴⁸Kolthoff and Sandell, "Textbook of Quantitative Inorganic Analysis", The Macmillan Company, New York, 1946, p. 507.

was observed in a period of one hour.

In Figures 1 and 2 are presented the infrared spectra of this compound and of some structurally related compounds. The spectra were obtained, using mulls in Nujol or hexachlorobutadiene, with a Baird infrared recording spectrophotometer. Runs were made by Mr. R.M. Hedges. The long wave length portion of the spectrum of the compound shows strong similarities with that of hydrazobenzene, indicating a similar type of substitution of the aromatic rings. The weak absorption peak at 3.9 microns suggests a quaternary nitrogen. Beyond this there is no clear evidence for the diconjugate acid structure since the spectral characteristics of the bond between two positively charged nitrogen atoms are not known. The absence of an absorption maximum in the region of 7.0-7.5 microns, when a hexachlorobutadiene mull is used, indicates the absence of terminal methyl groups. Thus there is nothing to indicate contamination of the diacid by the corresponding tetramethyl iodide.

The product was examined under a polarizing microscope by Mr. S. Flikkema. With all mounting media evidence was found for non-uniformity in the sample. However, crystals of one type form the bulk of the material and these crystals were found to be internally homogeneous. Their measured properties are: habit - prismatic; extinction - parallel; elongation - negative; refractive indices - 1.75 ± 0.01 , 1.65 ± 0.01 . The crystalline system is probably tetragonal. When the compound was mounted in methylene iodide a chemical reaction apparently took place, as a change of crystal type with time was observed.

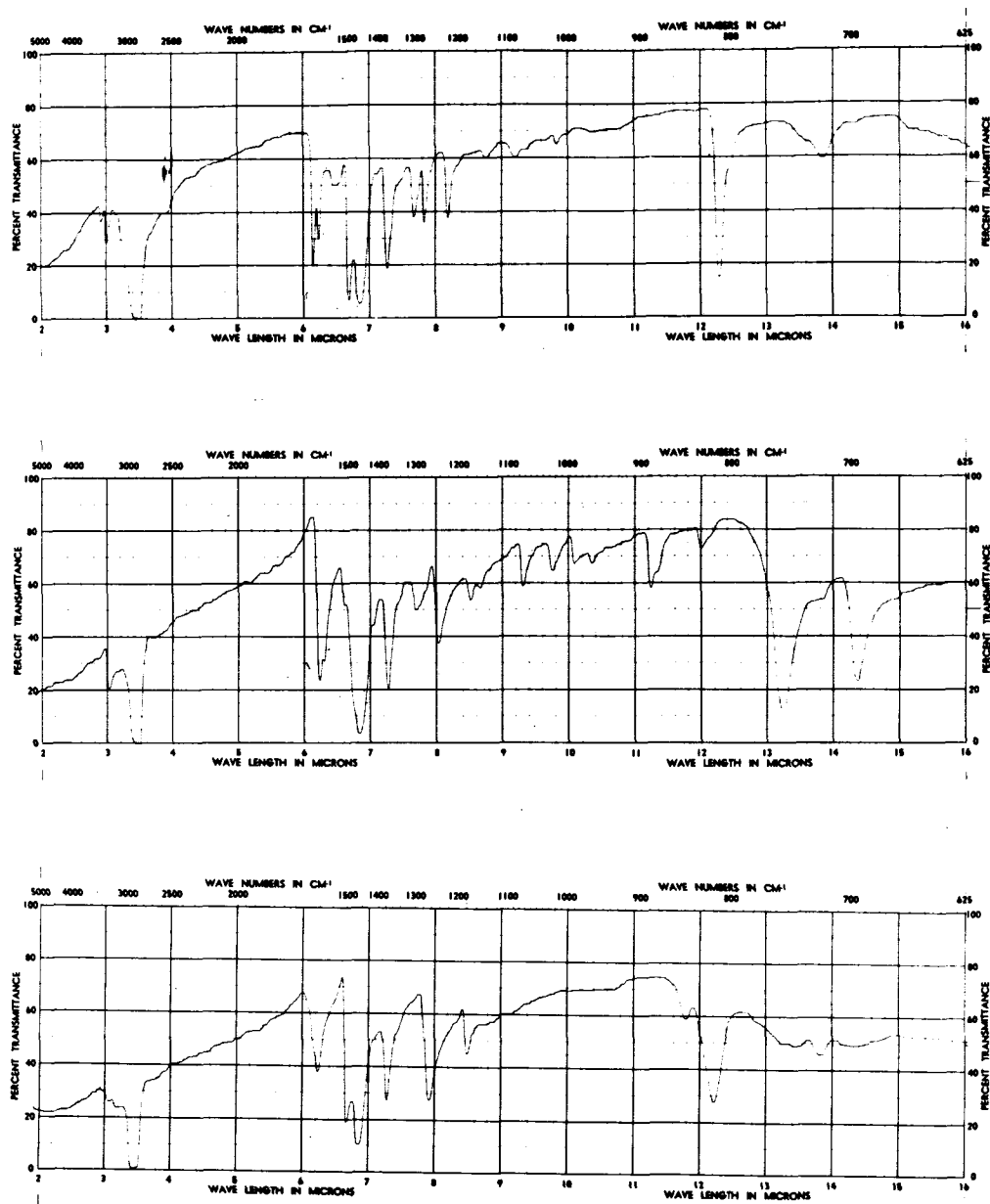

Figure 1. Infrared Spectra of Benzidine Dihydroiodide, Hydrazobenzene and Benzidine in Nujol Mulls.

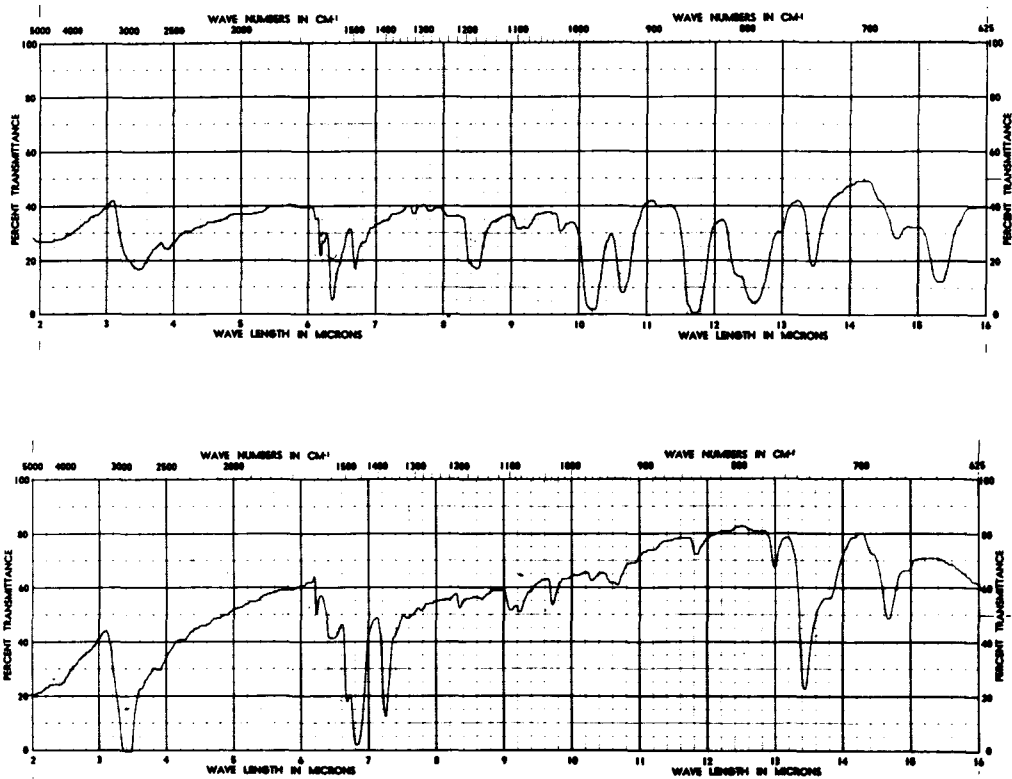

Figure 2. Infrared Spectra of Hydrazobenzene Dihydroiodide (?) in Hexachlorobutadiene and Nujol Mulls.

Benzidine dihydroiodide

Technical grade benzidine (Matheson Co.) was recrystallized three times from water, twice with decolorizing carbon. The resultant benzidine, which melts at 124.7°-125.0°C. (uncorr.), was dissolved in ether into which was then passed hydrogen iodide vapor. An immediate flocculent, light yellow, precipitate was formed. This was separated by filtration and dried. The salt does not melt or decompose below 300°C. The compound was found to be opaque in any mount under the microscope, and to disintegrate to a granular powder.

Other materials

Formic acid (90%, B. and A.); sodium formate (B. and A.); phosphoric acid (85%, Merck); chloroacetic acid (Eastmann); glycolic acid (Matheson) and cyanoacetic acid (Matheson) were used as supplied, without further purification.

Kinetic Procedure and Analytical Technique

All rates were measured for rearrangement at 55.1°C.

In the first section of the work the reaction vessel consisted of two flasks joined below their necks by a tube of one-half inch diameter. The acid and salt were dissolved in ethanol-water and placed in one flask. In the second flask was placed an appropriate volume of a solution of hydrazobenzene. The air in the vessel was flushed out with nitrogen and the two flasks closed. The flask containing the hydrazobenzene was equipped with an outlet tube which was kept closed by a small rubber stopper. Aliquots could be removed through this stopper by use of an hypodermic syringe.

This closed vessel was immersed in a conventional-type thermostat for an hour. The acid solution was then transferred to the second flask by tilting the vessel. The solutions were mixed thoroughly. The total transfer time was of the order of one-half minute, the time of tilt being taken as zero time for the kinetic run. Ten millilitre aliquots, of a total initial volume of 110 ml., were withdrawn and added to an excess of Bindschedler's Green solution, at appropriate intervals. The excess of the dye was determined by titration with titanous chloride solution in a nitrogen atmosphere. The dye solution was standardized against titanous chloride before and after each run to allow for the gradual decrease in the concentration of active dye. Thus the volume of titanous chloride equivalent to the hydrazobenzene in the aliquot was obtained.

In later work the reaction vessel used consisted of a single flask with a small indentation below the neck, into which solid hydrazobenzene was placed. The acid solution was put into the bottom of the flask. Kinetic results were obtained as before. It required about one minute for complete solution of the hydrazobenzene. For this latter stage of the study a new lot of Bindschedler's Green was prepared by the modified method described on page 23. This preparation was found to be stable in solution during the period of a kinetic run, within the limits of experimental accuracy, so that no correction was required.

For each rate determination a plot was made of the logarithm of the volume of titanous chloride (equivalent to the hydrazobenzene in the aliquot) against time after mixing. The best straight line through the points was calculated by the method of least squares. The pseudo-first

order rate constant was calculated from the slope of this line. Between six and ten points were obtained in each run.

Since disproportionation of hydrazobenzene into azobenzene and aniline occurs under certain conditions, several blank runs were made. A solution of hydrazobenzene in ethanol-water, with added salt but in the absence of acid, was placed in the thermostat. After an hour aliquots were withdrawn at intervals and treated as in the usual rate determinations. No change in the concentration of hydrazobenzene was observed over a further one hour period.

Variation of Reaction Rate with Change of Acid Catalyst

The first test for general acid catalysis consisted of an investigation of whether or not the rate depends on the nature of the acid present, under conditions of constant ionic strength and constant hydrogen ion concentration.

Solutions of acid catalyst, sodium ethoxide and lithium perchlorate, all in the same solvent, were prepared. The latter two solutions were of the same concentration. The acid was partially neutralized by addition of sodium ethoxide. Lithium perchlorate was then added and the pH measured with a Beckmann model-G pH meter. The same initial volume of acid was taken for all runs. The total volume of sodium ethoxide and lithium perchlorate added was kept the same throughout, thus maintaining constant ionic strength. A series of runs was made with each acid, the catalyst differing from run to run in a series in that different amounts of sodium ethoxide were added. Thus the pH-meter reading is a measure

of the degree of neutralization of the acid, and each run corresponds to a different hydrogen ion concentration.

The catalytic acids used in this study were phosphoric, chloroacetic, styphnic and formic acids. The runs with styphnic acid gave non-linear plots, possibly due to complexation with the hydrazobenzene, so rate constants were not obtained.

The results of this study are presented in Tables 3, 4 and 5, and are represented graphically in Figure 3. The solvent used throughout was 66%, by weight, aqueous ethanol. The temperature was $55.1^{\circ} \pm 0.06^{\circ}\text{C}$. The total salt concentration was 0.013 molar, maintained by use of lithium perchlorate.

Table 3

Catalysis by Chloroacetic Acid at Various pH's

[Chloroacetic acid] + [sodium chloroacetate] = 1.12 molar

Run No.	pH	10^5k (min^{-1})	$\Delta(10^5k)$ (min^{-1})
8	2.29	476	4.7
9	2.33	322	2.9
11	2.50	216	16.9
12	2.69	197	5.3
13	2.60	206	2.5

In the investigation of catalysis by chloroacetic acid some difficulty was caused by the slow conversion of the acid, in stock solution, to glycolic acid and chloride ion. For this reason the acid solution was utilized as soon after preparation as possible. The pH of an aliquot of this freshly prepared solution was found to remain constant when the aliquot was held at 55°C. for an hour, and the resultant solution gave no turbidity with silver nitrate.

The quantities $\Delta(10^5k)$ were derived from the probable errors involved in the slopes of the lines obtained by the method of least squares. If

Table 4

Catalysis by Formic Acid at Various pH's

[Formic acid] + [sodium formate] = 1.61 molar

Run No.	pH	10^5k (min. ⁻¹)	$\Delta(10^5k)$ (min. ⁻¹)
17	2.25	290	9.0
18	2.30	228	7.8
19	2.41	143	2.3
20	2.45	108	1.4
21	2.72	131	5.1

the calculated equation for the line representing the experimental data is:

$$y = mx + b,$$

and the i^{th} point has co-ordinates (x_i, y_i) , then the probable error⁴⁹ (r_m) in m is given by:

$$r_m = 0.6745 \left[\frac{n \sum (d_i)^2}{n(n-2) \sum (x_i)^2 - (n-2) (\sum x_i)^2} \right]^{\frac{1}{2}}.$$

Here n is the number of points in the plot and d_i is the deviation, in the y direction, of the i^{th} point from the calculated line.

During the runs with phosphoric acid a brown solid separated out. This solid was identified as benzidine phosphate. For this reason duplicate runs, numbers 25 and 27, were made, with and without addition of solid benzidine phosphate. No appreciable difference in rate was found.

⁴⁹Gibbs, "The Adjustment of Errors in Practical Science", Oxford University Press, London, 1929, p. 89.

Table 5

Catalysis by Phosphoric Acid at Various pH's

[Phosphoric acid] + [sodium phosphate] = 0.57 molar

Run No.	pH	$10^5 k^*$ (min^{-1})	($10^5 k$) (min^{-1})
22	2.20	2,425	47
23	2.30	1,972	0
24	2.39	1,652	0
25	2.41	1,534	16
26	2.48	1,401	4
27	2.41	1,590	6
28	2.48	1,265	5

*In calculation of the amount of lithium perchlorate to be added it was assumed that, at the low degrees of neutralization involved, only univalent ions are present.

Variation of Rate with Concentration of Undissociated Acid

The second test used in investigating whether the acid catalysis is general is the test usually applied⁵⁰. The solutions were buffered by use of an acid and its sodium salt. The ratio of acid to salt was constant throughout a series, but the absolute amount of acid varied from run to run. Constant ionic strength was maintained by adding the

⁵⁰Hammett, "Physical Organic Chemistry", McGraw-Hill Book Co., Inc., New York, 1940, p. 221.

calculated amount of potassium chloride. The effectiveness of the buffer action was checked by measuring the pH of each solution before use. A variation in rate from run to run in a series, under these conditions, indicates a dependence on the concentration of undissociated acid.

The acids used in this section of the work were formic, glycolic, chloroacetic, salicylic and cyanoacetic acids. The rate corresponding to zero concentration of undissociated acid, and, therefore, due to catalysis by hydrogen ion alone, was obtained from runs using hydrochloric acid - potassium chloride solutions of the same pH and ionic strength.

Some of the results for rearrangement catalysed by glycolic acid are reproduced in Figure 4. The concentrations of the acid are indicated in the diagram. The results are presented in Tables 6 to 10, and are collected in graphical form in Figure 5.

Table 6

Catalysis by Formic Acid at Fixed pH

Run No.	Acid Molarity	$10^4 k$ (min^{-1})
61	2.33	92
62	1.68	62
63	2.05	76
65	1.40	55
66	2.24	83
67	2.14	74
68	1.96	67

Table 7

Catalysis by Glycolic Acid at Fixed pH

Run No.	Acid Molarity	$10^4 k$ (min^{-1})
80	2.64	309
81	2.40	244
82	2.16	196
83	2.08	141
84	2.26	214
85	2.52	272
86	2.44	279
87	1.97	175
88	2.11	189
89	2.35	210
90	2.30	205

Table 8

Catalysis by Chloroacetic Acid at Fixed pH

Run No.	Acid Molarity	10^4k (min^{-1})
37	1.31	201
38	1.25	201
39	1.20	180
40	1.15	168
41	1.10	159
42	1.04	150
43	0.99	148
44	0.94	127
49	1.66	214
50	1.53	208
51	1.33	196
52	1.59	200
53	1.26	191
54	1.39	201
55	1.66	268
57	1.46	196
58	1.19	150
59	1.00	171

Table 9

Catalysis by Salicylic Acid at Fixed pH

Run No.	Acid Molarity	$10^4 k$ (min^{-1})
69	1.38	254
70	1.33	286
71	0.96	166
72	1.28	208
73	1.12	187
74	1.01	157
75	1.17	208
76	1.07	189
77	1.22	240

Table 10
Catalysis by Cyanoacetic Acid at Fixed pH

Run No.	Acid Molarity	10^4k (min. ⁻¹)
91	0.404	161
93	0.275	90
94	0.220	111
95	0.350	159
96	0.385	152
98	0.294	106
99	0.312	137
100	0.386	164
101	0.257	106
102	0.275	108
103	0.147*	55

*pH 2.49

The catalytic effect of each acid can be represented, approximately, by a linear increase of rate with concentration of acid with a positive deviation at high concentrations. The slopes of the linear portions have been taken as a measure of the catalytic constants of the various acids. Thus, for a point on the linear section of the rate vs. acid

concentration curve, the specific rate constant k is given by:

$$k = 0.0014 + k_1 [\text{HA}_1],$$

where the k_1 's are the catalytic constants. These constants are listed in Table 11.

Table 11
Catalytic Constants of Various Acids

Acid HA_1	Catalytic Constant k_1
Formic	$0.0027 \pm 0.0003^*$
Glycolic	0.0081 ± 0.0005
Chloroacetic	0.0133 ± 0.0010
Salicylic	0.0162 ± 0.0010
Cyanoacetic	0.0368 ± 0.0064

*Concentrations are expressed in moles per 1,000 gm. of solution, and rates in min^{-1} .

Attempted Application of the Bronsted Relation

Many reactions which are subject to general acid catalysis have been found to satisfy the Bronsted relation⁵¹:

$$\log k_{\text{HA}_1} = G + x pK_{\text{HA}_1},$$

⁵¹Bronsted and Pedersen, Z. phys. Chem., 108, 185 (1924).

where application is confined to one reaction of one substrate, and the various acids HA_1 are all of the same charge type.

A plot was made of the logarithms of the catalytic constants, listed in Table 11, against the pK values of the acids in water at 25°C. A similar plot was made against the approximate values of the pK values of the acids in 50% aqueous ethanol at 25°C., which are reported in the literature^{52,53}. In both cases no linear relation was found.

Attempted Isolation of the Rearrangement Step

Since the diconjugate acid of hydrazobenzene might be the species which actually rearranges, an attempt was made to prepare that acid and to compare its rate of rearrangement with that of the overall reaction. It has not been clearly established whether the diconjugate acid is, indeed, the product of the reaction of methyl iodide and hydrazobenzene at room temperature. In an ethanolic solution of the compound there is an initial decolorizing of added aqueous Bindschedler's Green. Such decolorization is no longer observed after a few seconds. Thus it would seem that there is some hydrazo- compound present in the ethanolic solution, but that rearrangement occurs very rapidly on the addition of a trace of water.

⁵²Minnick and Kilpatrick, J. Phys. Chem., 43, 259 (1939).

⁵³Harned and Done, J. Am. Chem. Soc., 63, 2579 (1941), and other references cited therein.

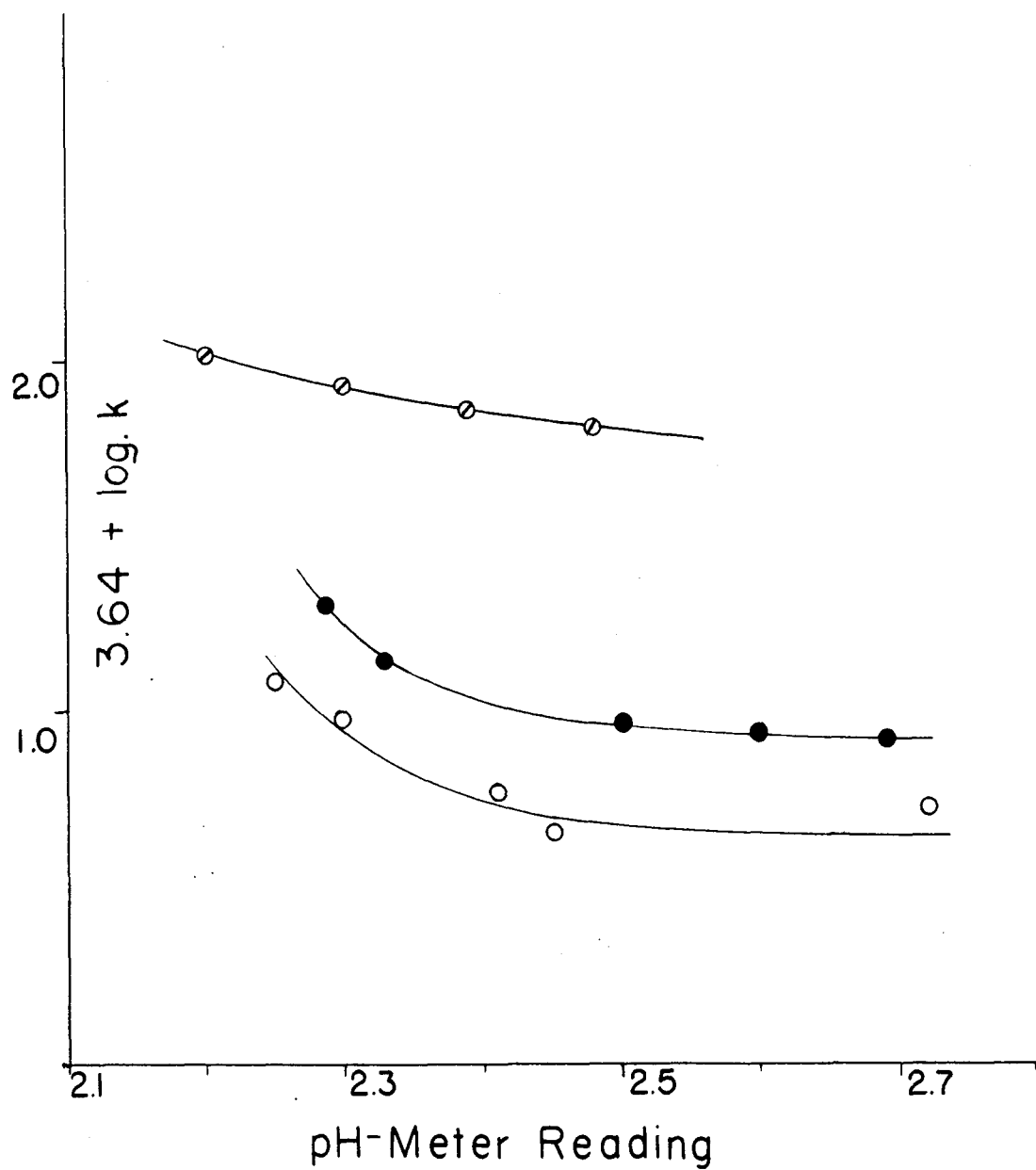

Figure 3. Logarithm of Rate vs. Apparent pH.

Phosphoric ○, Chloroacetic ●, Formic ○.

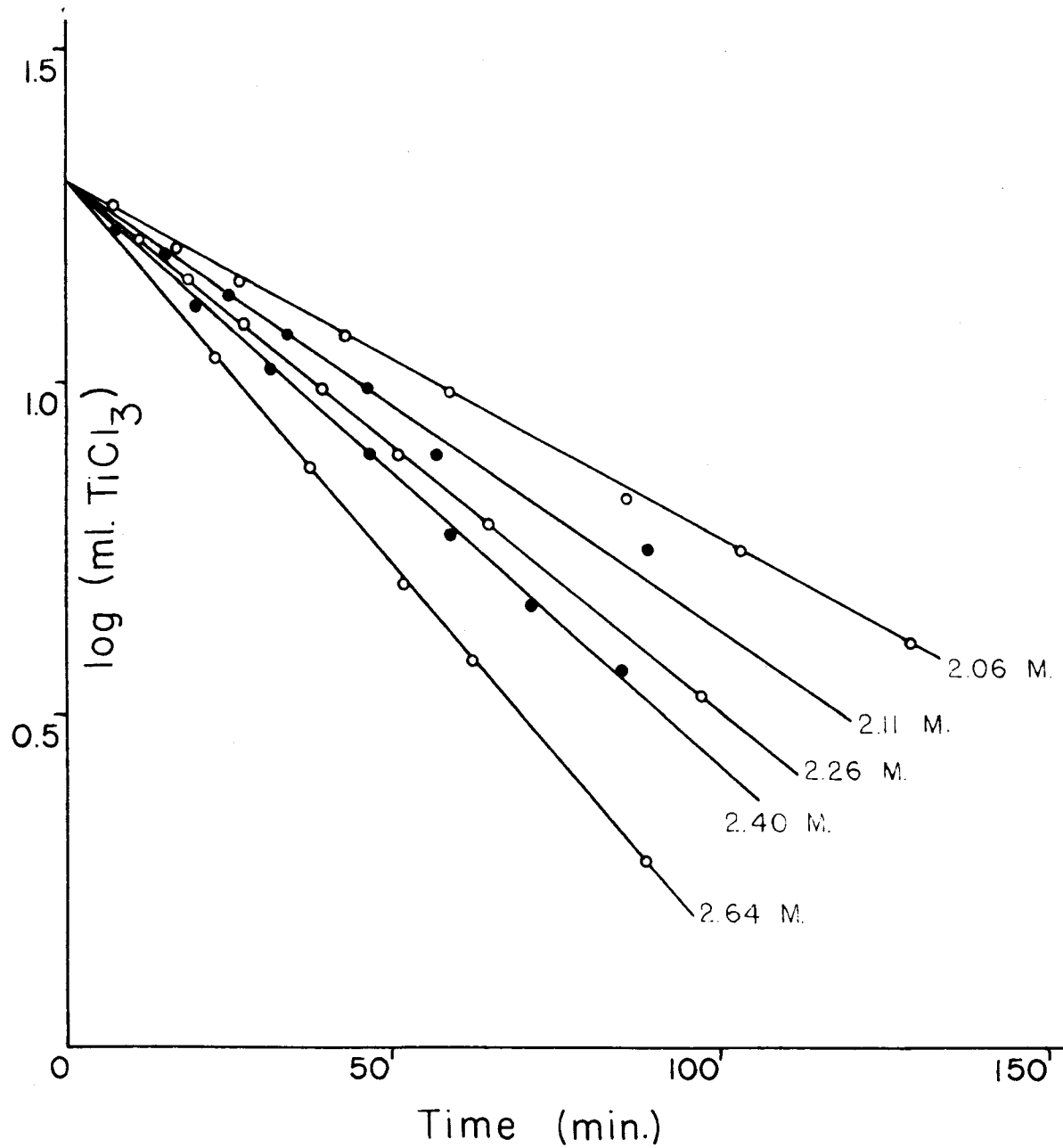

Figure 4. First Order Rate Plots for catalysis by Glycolic Acid of various concentrations.

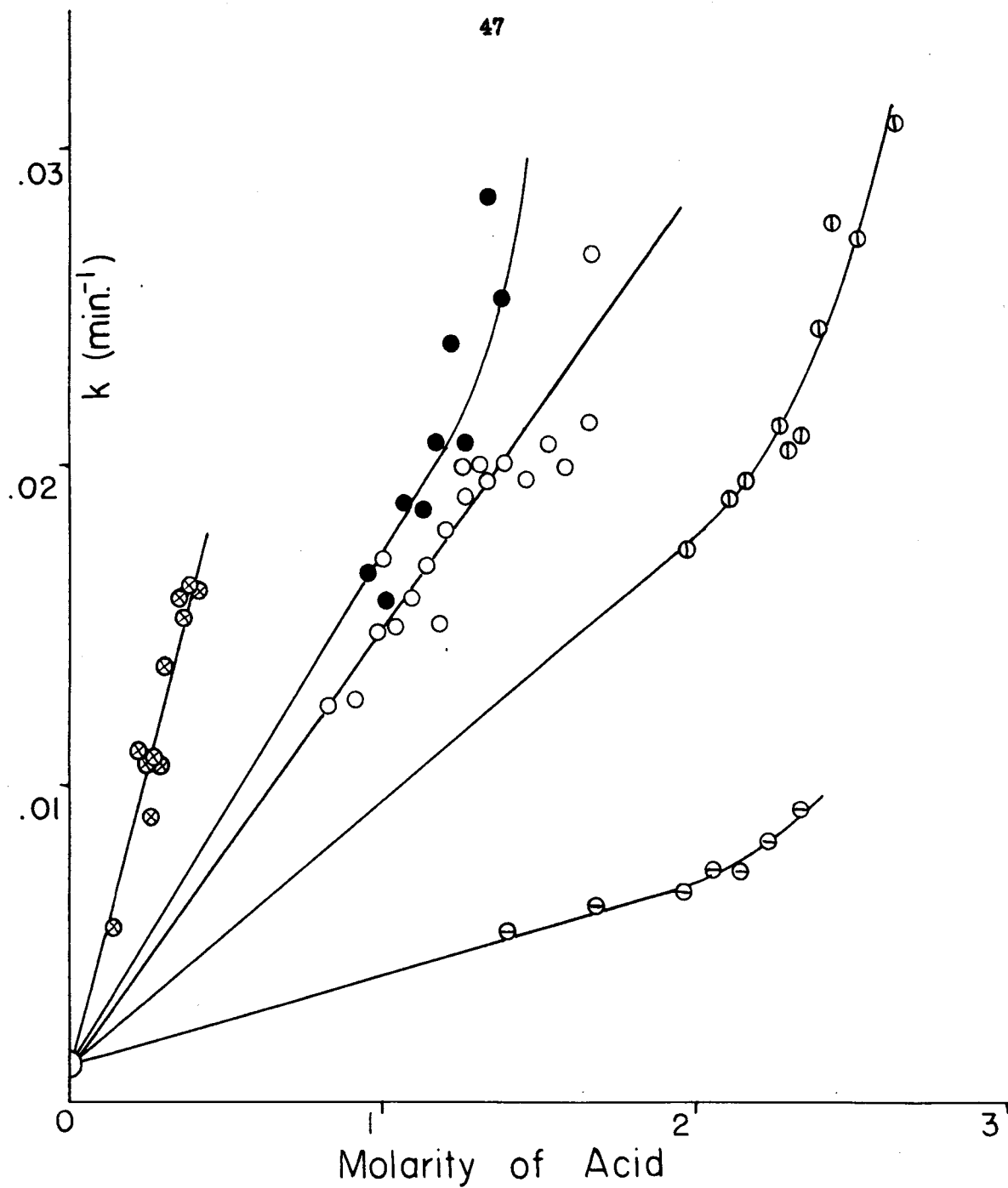

Figure 5. Rate vs. Molarity of Acid at constant pH.
Cyanoacetic ⊗, Salicylic ●, Chloroacetic ○,
Glycolic ⊕, Formic ⊖.

DISCUSSION

Limitations Inherent in the Experimental Method

An investigation of the type of acid catalysis to which the benzidine rearrangement is subject has to contend with several conflicting requirements. The conditions have to be so adjusted that the rate of the hydrogen ion catalysed reaction does not mask rearrangement catalysed by undissociated acid. Since the catalytic constant of hydrogen ion is relatively large, the hydrogen ion concentration must be kept low and constant. This entails buffering of the solutions and requires use of fairly weak acids. The catalytic constants of such acids are, however, correspondingly low. The rates of rearrangement catalysed by these acids are, therefore, inappreciable, unless both high temperatures and high concentrations of the acids are employed.

The use of elevated temperatures is limited by two factors. Disproportionation of hydrazobenzene is likely to become of importance at high temperatures. The second limitation is introduced by the use of aqueous ethanol as solvent. The utilization of another solvent is thus suggested. Water, for example, would be ideal, since it is higher boiling and since pH readings for aqueous solutions are interpretable. However, hydrazobenzene is insoluble in water, and soluble hydrazobenzene derivatives introduce complications as regards ionic strength. Other higher boiling solvents are unacceptable because pH meter readings for such solvents are meaningless, at our present state of knowledge.

The conditions employed were considered to be the most acceptable

compromise ones. There remain the questions of the meaning of constant pH meter reading in these solutions, and of the magnitude of the effects produced by variations in the nature of the solvent at high acid concentrations.

It has been shown by Dole⁵¹ that the negative error exhibited by the glass electrode in non-aqueous solvents can be explained on the basis of solvation of the proton. According to this author the electrode will always be in error when the activity of water in the solution differs from unity. This theory predicts that the error will be constant for solutions in which the activity of water is a constant. Although this theory has not been unequivocally established, it suggests that, in the absence of large disturbing effects by dissolved acids, the variation in hydrogen ion concentration is not large.

Little can be said about the perturbing effects of the acids on pH readings in such mixed solvents. There are, however, sources of comfort. Under the conditions employed in this investigation the observed variation in rates was large compared to the rate of the hydrogen ion catalysed reaction. The variation is not, therefore, attributable to relatively minor changes in hydrogen ion concentration. In addition, the large changes in rate found with the stronger acids, where smaller concentrations were employed, suggest that the variation in hydrogen ion concentration at constant pH meter reading is not a determining factor.

Equally important is the question of variation in the reaction rate,

⁵¹Dole, J. Am. Chem. Soc., 54, 3095 (1932).

at constant hydrogen ion concentration, due to changes in the nature of the medium. It is known, for example, that the rate of rearrangement is sensitive to the dielectric constant of the solvent. Here again the magnitude of the variation with stronger acids supports the contention that the effect observed is due mainly to changes in the concentration of undissociated acid.

It is felt, however, that the positive deviations from linearity observed with all acids at high concentrations (Figure 5) may be due to medium effects. This explanation is offered only since the writer has found no more satisfactory one.

Because of the nature of the analytical technique, the rates studied were those of disappearance of hydrazobenzene and, probably, of its first conjugate acid. The results are, nevertheless, interpretable in terms of the rates of formation of both benzidine and diphenylene, since Carlin⁴¹ has shown that the rates of formation of both these compounds have the same hydrogen ion dependence and the same activation energies.

The Information Gained from this Study

It can be seen from Figures 3 and 5 that the rate is dependent on the particular acid catalyst, at constant pH meter reading. Figure 5 also shows that the rate varies with the concentration of added acid, under the same conditions. Within the limitations imposed by medium effects on reaction rates and on the potential differences established at a glass electrode, these conditions may be taken as corresponding to

constancy of hydrogen ion concentration. Thus, it has been established that the rate of rearrangement varies with the concentration of undissociated acid present.

The studies on the compound which has been reported to be hydrazobenzene dihydroiodide are less definitive in that no unequivocal evidence concerning the structure of the compound was obtained. Pongratz³⁹ showed that solution of this compound led to the formation of benzidine. Carlin⁴² obtained a solid compound which he believes to be hydrazobenzene dihydrochloride, but in aqueous solution only benzidine was found. The least that can be said, then, is that no indication has been obtained for the final step being slow. In fact, all tests applied to the above compound suggest that it rearranges very rapidly at room temperature, in the presence of water.

Implications of the Kinetics

Consider the acid catalysed reaction of a compound X.

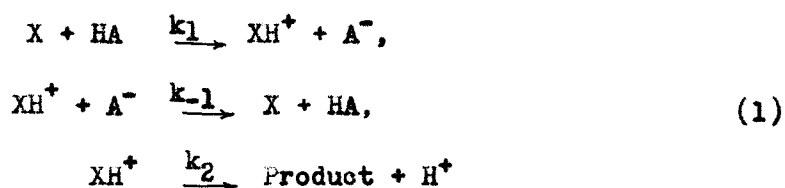

If XH^+ is a stronger acid than HA, probably k_{-1} is correspondingly larger than k_1 . Under these conditions the concentration of XH^+ soon attains a steady state. The rate of formation of XH^+ is given by:

$$\frac{d[XH^+]}{dt} = k_1[X][HA] - k_{-1}[XH^+][A^-] - k_2[XH^+] .$$

This gives for the concentration of XH^+ , under steady state conditions,

$$[XH^+] = \frac{k_1[X][HA]}{k_{-1}[A^-] + k_2} .$$

Then the rate of formation of products is:

$$\begin{aligned} \text{Rate} &= k_2[XH^+] \\ &= \frac{k_2k_1[X][HA]}{k_{-1}[A^-] + k_2} . \end{aligned} \quad (2)$$

When $k_{-1} \gg k_1$ there are two limiting cases which can be considered.

If $k_2 \ll k_{-1}$, the rate becomes:

$$\text{Rate} = \frac{k_1k_2[X][HA]}{k_{-1}[A^-]} .$$

Since $[HA]$ and $[A^-]$ are effectively constant in any run, and are related by the equation

$$[HA]K_{HA} = [H^+][A^-] , \quad (3)$$

the measured rate is

$$\text{Rate} = k_1k_2K_{HA}^{-1}[H^+][A^-] .$$

The second limiting case is $k_{-1} \ll k_2$. The measured rate is then

$$\text{Rate} = k_1[X][HA] , \quad (4)$$

the addition of a proton to X then being rate-determining. Between these

two limits the dependence on acid concentration is a fractional one.

Specifically, if the first step in the rearrangement is the rapid equilibration

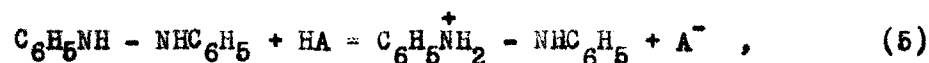

where the first conjugate acid follows a sequence such as outlined for compound X in (1), then the kinetics can be treated similarly. In assigning relative magnitudes to the various rate constants it must be borne in mind that the rearrangement is of second order in hydrogen ion, when the catalyst is a mineral acid. The rate is a function of the concentration of undissociated acid, when weaker acids are employed.

Since the addition and removal of the first proton must be fast, the initial step, as written in (5), cannot be kinetically differentiated from

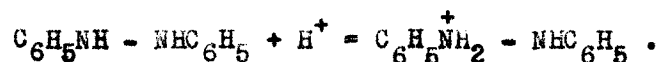

Because the rate varies in a linear manner with the concentration of undissociated acid, at moderate concentrations, the addition of the second proton leads to an equation such as (4) and must be rate-determining.

If the deviation from linearity at high concentrations is not due to the change in the nature of the medium, then the two molecules of undissociated acid must participate in the slow step:

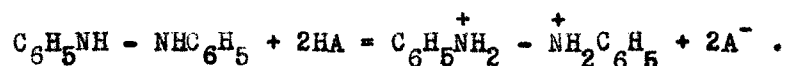

Such a termolecular process is not considered probable.

Because of the existence of the acid equilibrium represented in (3), a dependence on the concentration of undissociated acid is not kinetically

distinguishable from a dependence on the product of the concentrations of hydrogen ion and anion A^- . Further, the system of process (1) will give the same kinetic results as the concerted process:

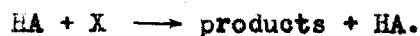

The idea of a concerted process is considered with disfavor for other reasons. All the work with salts of the diconjugate acid of hydrazobenzene suggests that that acid rearranges rapidly. This cannot be explained in terms of re-equilibration with the first conjugate acid prior to rearrangement, as such a sequence of steps would not proceed faster than the overall process. Further, if the process is concerted then the energies of activation would, in all probability, be different for the formation of benzidine and diphenylene. These energies, however, are found to be the same. An experimental test of whether or not the process is concerted could be made by comparing the rates of rearrangement of hydrazobenzene and of hydrazobenzene labelled with deuterium in the 4 and 4' positions.

The Nature of the Transition-State

The kinetic results show that the benzidine rearrangement, when catalysed by undissociated acid, proceeds through a transition-state involving an hydrazobenzene molecule, two protons and an acid anion. It has not been established whether anions participate in the catalysis by mineral acids. Any discussion of the relative arrangement of the groups in, or configuration of, the transition-state must be largely conjectural.

The most obvious formulation of the rate-determining step is that of a proton transfer from a neutral acid molecule to the neutral nitrogen in the first conjugate acid of hydrazobenzene. If this is the case, the geometrical relationships between the various participating entities, in this step, can be closely approximated. The concerted process, on the other hand, is formulated as the transfer of a solvated proton to neutral nitrogen, with simultaneous removal of a proton from a para carbon by an anion.

Because of the adjacent positively charged nitrogen it is conceivable that the second proton enters the complex at an alternative position, and does not bond to nitrogen in this step. The proton might, for example, enter into a π -complex with the benzene ring to which the neutral nitrogen is attached. It is believed, however, that these structures are energetically less favorable than the structure involving two adjacent positive charges, for they involve the partial loss of the resonance energy of one benzene ring, while the energy due to electrostatic repulsion is still appreciable. The same would be true of structures such as XV and XVI, which are of the type postulated by Brown⁵² as more probable than π -complexes. In addition, the course of the actual rearrangement step, proceeding from such intermediates, would be of considerable complexity.

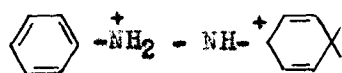

XV

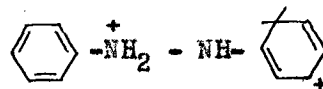

XVI

⁵²Brown and Pearsall, *J. Am. Chem. Soc.*, **74**, 191 (1952).

It is therefore suggested that the path of lowest activation energy corresponds to the transfer of a proton from undissociated acid to neutral nitrogen. It remains to enquire whether any information can be obtained about the location of the transition-state in the reaction co-ordinate.

The method which has been used most for gaining information concerning configurations and energies of transition-states is the semi-empirical one of Eyring and Polanyi⁵³. In general, a four dimensional space is required for the potential energy figure of a three component system. Proton transfer reactions allow of a considerable simplification in that two of the three entities can be treated as stationary during the reaction. At a first glance it would seem that the system of interest here could be treated particularly simply by this method. Thus, because of the charge distribution in the reactants, a linear configuration seems probable, in which case a two - dimensional potential energy diagram suffices. In addition, in a reaction of this sort, which involves extensive electron redistribution, the perturbation, or resonance stabilization, of the transition-state should be small⁵⁴. Information about such a system should, therefore, be derivable from consideration of the dissociation curves of -O-H and $\ddagger\text{N-H}$.

Bell⁵⁵ has made such calculations for systems of the type



Unfortunately, in the benzidine rearrangement we are interested in

⁵³Eyring and Polanyi, Z. physik. Chem., B., 12, 279 (1931).

⁵⁴Evans and Polanyi, Trans. Faraday Society, 34, 14 (1938).

⁵⁵Bell and Lidwell, Proc. Roy. Soc., A., 176, 114 (1940).



Here the electrostatic field changes during reaction, and a large solvation effect is expected. The magnitude of this effect is not calculable.

For this reason only a simplified and comparatively crude calculation has been undertaken. For the process

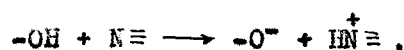

using the values:

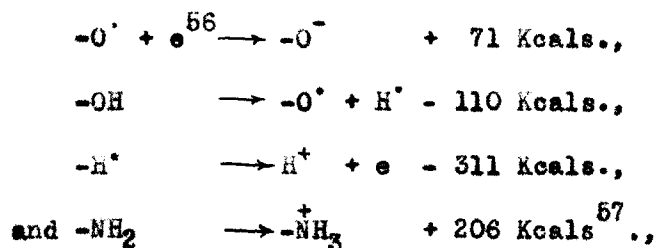

the overall energy change is calculated to be -144 Kcals. per mole. An increase of solvation energy of a similar magnitude is probable⁵⁸. In this case the bases of the two potential energy curves would be at similar levels. However, because of the positive charge initially present in the hydrazo-compound, an additional electrostatic energy is involved. Using a linear model for the two nitrogens, hydrogen and oxygen, with somewhat arbitrary values for the dielectric constants and internuclear distances, a value of 15 Kcals. per mole was calculated for the added energy of the

⁵⁶Vier and Mayer, J. Chem. Phys., 12, 28 (1944).

⁵⁷Syrkin and Dyatkina, "Structure of Molecules and the Chemical Bond", Interscience Publishers, Inc., New York, 1950, p. 115.

⁵⁸Kortum and Boekris, "Textbook of Electrochemistry", Elsevier Publishing Co., Amsterdam, 1951, p. 120.

transfer process. This would elevate the base of the nitrogen - hydrogen curve to a point close to the intersection of that curve with the oxygen - hydrogen curve. The configuration of the transition-state, by this token, is close to that of the diconjugate acid.

The Nature of the Rearrangement Step

As the reaction proceeds beyond the transition-state the potential energy decreases, probably because of the formation of the hydrogen - nitrogen bond. Beyond this the energy must go through a minimum and a maximum before formation of the products. The height of the maximum must be different for the formation of benzidine and of diphenylene, being smaller for the latter.

The fact that the diconjugate acid can rearrange indicates that there is resonance stabilization of the intermediate structures. The arguments of Hughes and Ingold⁴⁰ are applicable to this step. The initial decrease in energy indicates that interactions between the para carbons is effective over a considerable distance. The maxima corresponds to the decreased nitrogen - nitrogen bonding and, possibly, to repulsion between non-bonded carbon and hydrogen.

The Thermodynamics of Pre-equilibration

It is interesting to speculate as to whether it can be determined, by a quantitative study of the variation in rate with dielectric constant or ionic strength, if the addition of the second proton or the actual rearrangement step is rate-determining. In order to be able to discuss this problem it is necessary to investigate the thermodynamic basis of pre-equilibration.

Consider the equilibria



and the corresponding thermodynamic equilibrium constants

$$K_1 = \frac{(a_M)^m (a_N)^n \dots}{(a_B)^b (a_C)^c \dots} = e^{-\Delta F_{0,1}/RT}$$

$$K_2 = \frac{(a_W)^w (a_X)^x \dots}{(a_M)^m (a_N)^n \dots} = e^{-\Delta F_{0,2}/RT} .$$

We see that there is a valid equilibrium constant

$$K = K_1 K_2 = e^{-(\Delta F_{0,1} + \Delta F_{0,2})/RT}$$

for the equilibrium



According to the theory of absolute reaction rates, the rate, R , of

a reaction is given by⁵⁹

$$R = \frac{\bar{v}c^\ddagger}{\delta} = \chi \frac{kT}{h} c^\ddagger, \quad (7)$$

where c^\ddagger is the concentration of the activated complex, or transition-state, and \bar{v}/δ is the average frequency of passage over the potential barrier. According to this theory the population of the transition-state can be treated as a molecular species which is in equilibrium with the reactants. The corresponding equilibrium constant is written

$$K^\ddagger = \frac{a^\ddagger}{\prod_r a_r},$$

where the a_r 's are the activities of the reactants. Then

$$c^\ddagger = K^\ddagger \frac{\prod_r a_r}{\gamma^\ddagger}.$$

Substituting this value in (7), the rate expression becomes

$$\begin{aligned} R &= \chi \frac{kT}{h} \frac{\prod_r a_r}{\gamma^\ddagger} K^\ddagger \\ &= \chi \frac{kT}{h} \frac{\prod_r a_r}{\gamma^\ddagger} e^{-\Delta F_0^\ddagger/RT}. \end{aligned} \quad (8)$$

⁵⁹ Glasstone, Laidler and Eyring, "The Theory of Rate Processes", McGraw-Hill Book Co., Inc., New York, 1941.

Equation (8) is a restricted form of the Bronsted rate-equation⁶⁰.

There has been some speculation as to whether there can be an effective maintenance of equilibrium, either before the rate-determining step, or in that step. It seems, however, that the maintenance of both these equilibria can, at least, be closely approximated. On this basis, consider the process



By applying equations (6) and (8), the rate is found to be

$$R = \kappa \frac{kT}{h} \frac{(a_B)^b (a_C)^c \dots}{\gamma^\ddagger} e^{-(\Delta F_{O,1} + \Delta F_O^\ddagger)/RT} \quad (9)$$

and we can write

$$\Delta F_{O,1} + \Delta F_O = (\Delta F_O^\ddagger)^\ddagger .$$

However, if the transition-state is intermediate in configuration between B,C,.... and M,N,...., the rate equation would be

$$R = \kappa \frac{kT}{h} \frac{(a_B)^b (a_C)^c \dots}{\gamma^\ddagger} e^{-(\Delta F_O^{\ddagger\ddagger})/RT} . \quad (10)$$

In the benzidine rearrangement the steps in question are

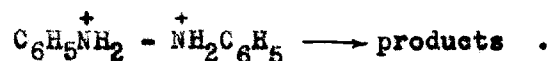
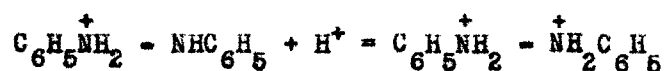

⁶⁰Bronsted, Z. physik. Chem., 102, 169 (1922).

The dominant change in activity coefficients with changing ionic strength or dielectric constant is due to the charge and charge-type of the species. Thus, comparing equations (9) and (10), it is seen that as γ^\ddagger applies to a doubly-positive charged species in both cases, both would give the same rate dependence on, say, ionic strength.

Thus, ionic strength and dielectric constant studies can support or discredit the hypothesis that the transition-state bears two positive charges. They can give no information as to the relative location of that state. This brief analyses points out that kinetic results which can be taken to indicate that a certain step is the slow one, can also, often, be interpreted in terms of a pre-equilibration.

The Bronsted Relation

The Bronsted relation has never been "derived" but its implications are clear. Consider rate equation (8),

$$k = \kappa \frac{kT}{h} \frac{\prod a_r}{\gamma^\ddagger} K^\ddagger,$$

as applied to the process



where B is a base such as hydrazobenzene. If the activities of B and of hydrogen ion are maintained constant, a_{BH^+} will also be constant. Further, when all acids HA are of the same charge type, γ^\ddagger will be

constant, too. Under these conditions equation (8) simplifies to

$$R = CK^{\ddagger}, \quad (12)$$

where C is constant.

The Bronsted relation suggests that it is the "intrinsic acidities" of the acids HA which cause the variations in K^{\ddagger} and, therefore, in R. The standard method of measuring acidities utilizes the system

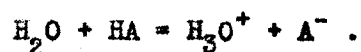

The corresponding equilibrium constants are the standard ionization constants

$$K_1 = \frac{a_{H_3O^+} a_{A^-}}{a_{H_2O} a_{HA}} \quad (13)$$

which must be compared with

$$K^{\ddagger} = \frac{a_{BH^+} \dots a_{H^+} \dots a_{A^-}}{a_{BH^+} a_{HA}}.$$

Because of the different charge types involved, K_1 and K^{\ddagger} probably do not vary linearly with one another. This can be seen more readily if we modify the transition-state so that (11) becomes

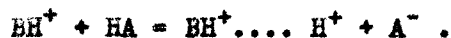

For this case

$$K^{\ddagger} = \frac{a_{BH^+} \dots a_{H^+} a_{A^-}}{a_{BH^+} a_{HA}}$$

$$\text{and } \frac{k^{\ddagger}}{k_1} = \frac{a_{\text{BH}^+} \dots a_{\text{H}^+} / a_{\text{BH}^+}}{a_{\text{H}_3\text{O}^+} / a_{\text{H}_2\text{O}}} .$$

Hammett⁶¹ has shown that activity coefficient ratios of the form

$\frac{\gamma_{\text{DE}^+} / \gamma_{\text{D}}}{\gamma_{\text{EH}^+} / \gamma_{\text{E}}}$ are constants in media of reasonably high dielectric constant,

when D and E are bases of the same charge type. However, this constancy no longer holds when the charge types differ. Thus, non-linearity is to be expected when the rearrangement rate constants are compared with the standard ionization constants of the acid catalysts.

Hammett⁶¹ has defined a function, H_+ , which is a measure of the strength of a solution in transferring a proton to a positively charged base. This function can be determined colorimetrically, with the aid of suitable indicators. It would be of interest to compare the rates of rearrangement catalysed by mineral acid solutions with the H_+ values of these solutions.

It should be pointed out that too few acids were employed in the study here reported to enable an analysis of the deviation from linearity. It is possible, for example, that some of the acids used introduce special catalytic influences or specific medium effects about which we have no information.

⁶¹Hammett, Chem. Rev., 16, 67 (1935).

SUMMARY

It is shown that the rate of the acid catalysed benzidine rearrangement varies with the nature and the concentration of undissociated acid, under conditions of constant ionic strength and constant pH meter reading.

The meaning of these conditions is discussed and interpreted as indicating approximately constant activity of hydrogen ion, at moderate acid concentrations. It is shown that the kinetic results suggest a transition-state composed of an hydrazobenzene molecule, two protons and an acid anion. From consideration of the energetics of the reaction, it seems that the configuration of the transition-state is not far removed from that of the diconjugate acid of hydrazobenzene. It is proposed that the actual rearrangement step is relatively rapid. This contention is supported by the properties of a compound believed to be hydrazobenzene dihydroiodide.

The thermodynamics of pre-equilibration is employed to demonstrate that studies of the ionic strength dependence of the rate cannot show which of the two possible steps is the rate-determining one. The catalytic constants of the acids do not obey the Bronsted relation. It is suggested that a more valid correlation would be with Hammett's H_+ function.